

# EasyCurve™ Multi-Bucket Cart User's Guide

Instructions for joining two caster bases (2728) into a multi-bucket cart.  
Requires one connecting kit (2729)

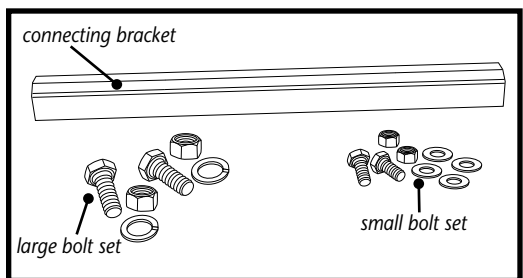

Connecting Kit (2729) Components

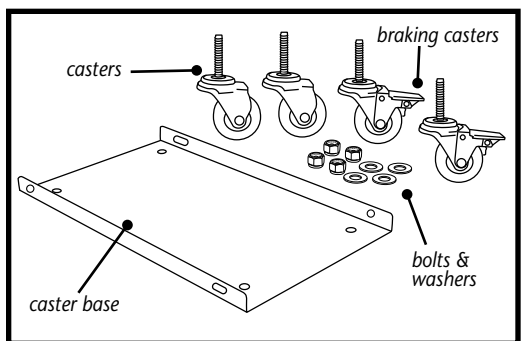

2728 Components

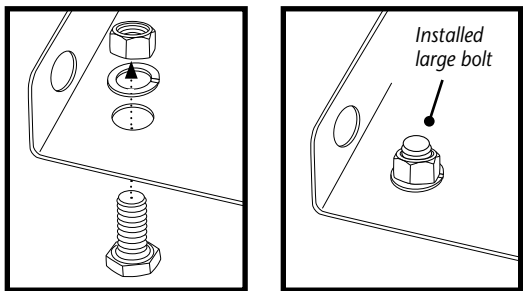

Step 5/ Installing large bolt in hole in  
caster base

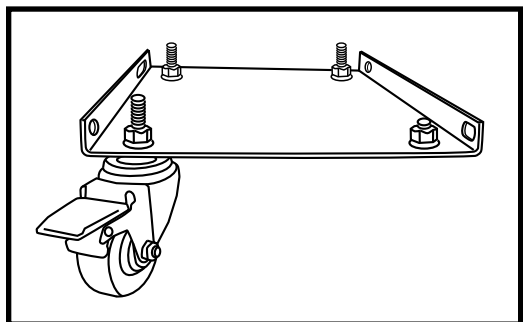

Step 6/ Fully assembled caster base

## EasyCurve Caster Base Assembly:

1. Remove the stainless steel caster base, 4 swivel casters, 4 nuts, and 4 washers from their packaging. Open the connecting kit (2729) which contains a stainless steel connecting bracket, 2 sets of bolts, nuts, and washers— one large, one small. Properly dispose of packaging materials. You will need two wrenches to assemble the casters to the base.

**NOTE:** Two of the casters have a foot-activated brake mechanism.

2. Insert the threaded stud of one caster into one of the four holes in the bottom of the caster base. The caster wheels should be on the bottom of the caster base.
3. With the threaded stud of the caster extending through the caster base, place a washer onto the stud, then fully thread a nut onto the stud, being careful not to cross-thread it. Hold the underside of the caster with one wrench. Using the second wrench, tighten the nut on the top of the caster base (approximately 60 ft-lb. torque).
4. Repeat steps 2 & 3 until there are one non-braking and two braking casters attached to the caster base.

**NOTE:** For maximum stability and brake-holding effectiveness, it is recommended that the braking casters be installed adjacent to each other along the longer side of the caster base, NOT the shorter side.

5. Place one large bolt from the connecting kit (2729) into the remaining hole in the underside of the caster base. Thread with washer and bolt (from 2729) and tighten to approximately 60 ft-lb. of torque.
6. Repeat steps 1 - 5 to assemble the second caster base (2728). You should now have two caster bases assembled with a total of 6 casters.

**NOTE:** The 2 remaining casters will NOT be used in this multi-bucket system and should be saved in the unlikely event a replacement caster is needed.

Instructions for assembling 2 caster bases  
into a multi-bucket cart and installing  
buckets are on page 2 →

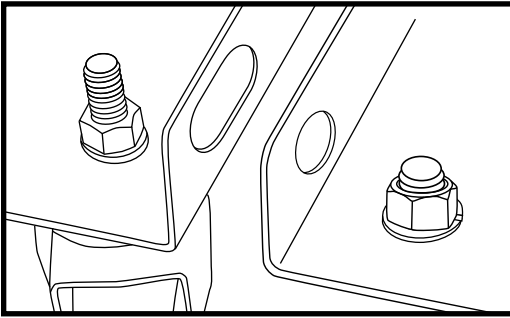

Step 1/ Aligning holes and slots in the two bases.

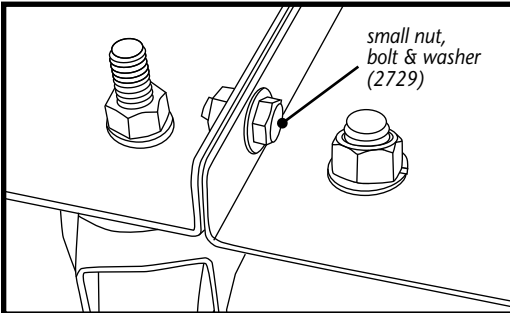

Step 2/ One small nut, bolt and washer set fully assembled through the slot and hole in the two caster bases.

### Joining Two Caster Bases:

1. Place both assembled caster bases (with 3 casters each) side by side on a level surface. The joining sides should be the side with one caster. The single casters should be at opposite ends of the two joined caster bases. Align the holes with the slots on the sides of the caster bases.
2. Take the set of smaller nuts, bolts and washers from the 2729 multi-bucket kit. Place one bolt through the first hole/slot on the side of each caster base. Place a washer onto the stud, then thread a nut fully onto the stud, being careful not to cross-thread the nut.
3. Hold the top of the bolt with one hand and use a wrench to tighten to approximately 60 ft-lb. of torque.
4. Repeat steps 2-3 with second bolt at the other end of the joined caster bases, inserting the bolt from the opposite side of the joined caster bases.

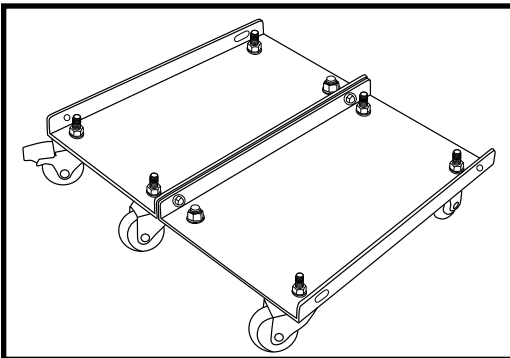

Assembled multi-bucket cart

### Bucket Installation:

1. Place the assembled multi-bucket caster base on a flat, level floor.
2. Position the red EasyCurve™ Bucket (UBKT0002) over one caster base so that three threaded studs of the casters are directly under the corners of the bottom of the bucket. Push firmly into place. Position the blue EasyCurve™ Bucket (2726 or UBKT0001) over the other caster base, so that the threaded studs of the casters are directly under the corners of the bottom of the bucket. Push firmly into place. Ensure that the buckets are resting completely and evenly on the threaded studs.
3. Add the Slinger™ frame (from 2726) to the non-graduated side of the red EasyCurve Bucket (UBKT0002) and hang the fabric mesh Slinger from the rods provided.
4. Place the stainless steel connecting bracket from the connecting kit (2729) over the touching sides of the blue and red bucket. This bracket secures the two buckets together and helps to prevent drips and leaks. The EasyCurve multi-bucket cart is now ready for use.

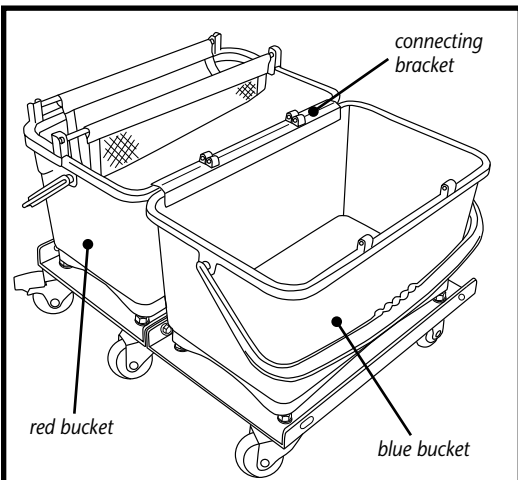

Buckets and Slinger™ installed on assembled multi-bucket cart